 INSTALLATION INSTRUCTIONS	Accessory PAX SPARE TIRE KIT	Application ODYSSEY	Publications No. AJA41932
			ISSUE DATE JUN 2009

PARTS LIST

PAX Spare Tire Kit

Quantity	Contents of Kit	
1	Tire and wheel assembly	
1	Spacer Cone	
1	Bolt, Spare Tire (Wing bolt)	
1	Bracket Assembly, Spare Tire	
1	Driver's side door label with tire pressures for both spare and PAX	
1	Vinyl Storage Bag	
1	Spare tire kit Instructions (this document)	

INSTALLATION

1. Open the tailgate. Remove the spare tire cover by holding the two handles and pulling the cover.

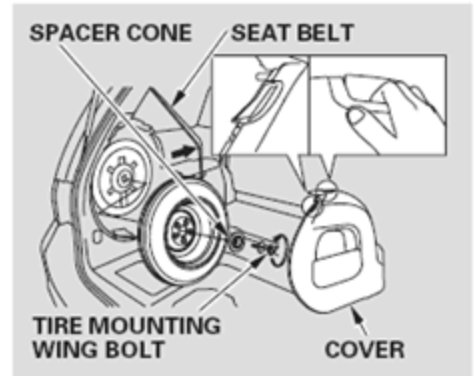

2. Place the spare tire in the panel recess. Insert the wing bolt through the spacer cone and the center of the spare tire. Thread the wing bolt into the body and tighten it securely.
3. Reinstall the spare tire cover.
4. Press the two tabs and remove the jack cover.
5. Install the spare tire bracket and vinyl storage bag behind the jack. (If the vehicle is already equipped with the spare tire bracket, discard the bracket from the kit).

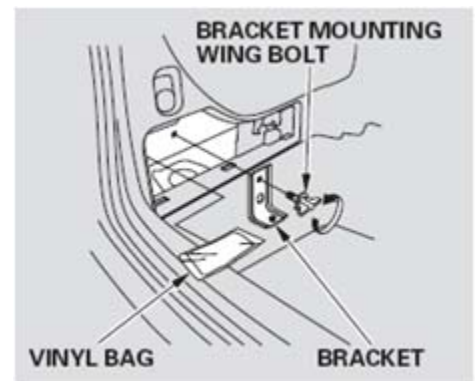

6. Reinstall the jack (if removed) and jack cover.

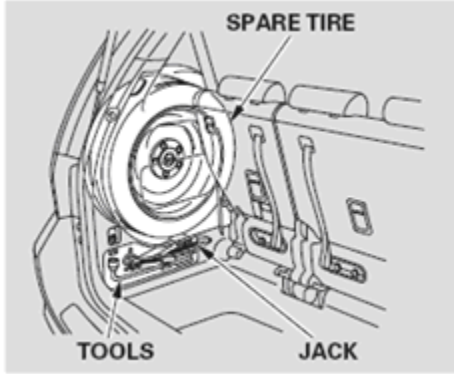

7. Fold this paper in half and place it in the owner's manual in the section called "Driving with a Flat Tire."
8. Apply the door label (showing the tire pressures for the spare and the PAX tires) on top of the existing tire pressure label on the driver's door jamb. Clean the surface of the existing label before installing the new label.

Using the compact spare tire on PAX equipped vehicles

- A PAX tire is very heavy (72 lbs). Be careful when moving a PAX tire in or out of the vehicle; if necessary, get assistance to lift the wheel and tire assembly.
- Refer to the "Changing a Flat Tire" section of the vehicle owner's manual to install the compact spare tire.
- The "PAX SYSTEM WARNING" messages may be displayed when using the spare tire. This is normal. Refer to the "Driving With a Flat Tire" section of the vehicle owner's manual for compact spare tire usage.