



## INSTALLATION INSTRUCTIONS

Accessory  
**BICYCLE ATTACHMENT**  
 P/N 08L07-E09-100

Application  
 2011 ODYSSEY

Publications No.  
**All 43929**

Issue Date  
**SEPT 2010**

Put this information in the glove box with the vehicle owner's manual.

### PARTS LIST

Bicycle attachment

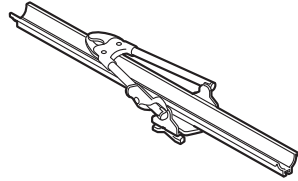

Hex wrench

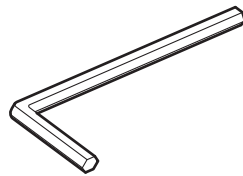

2 Keys



2 Wheel straps

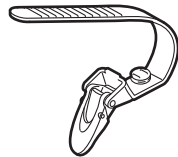

2 Tire adapters



2 End caps

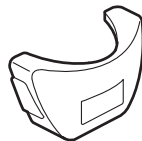

4 Bolts



4 Washers



2 Brackets



4 Knobs



Rear plate

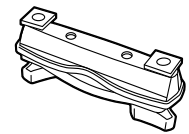

### TOOLS AND SUPPLIES REQUIRED

Tape measure

*Illustration of the Bicycle Attachment Installed on the Vehicle*

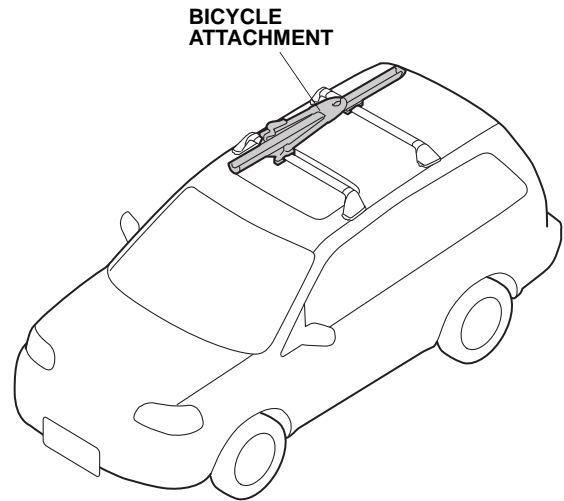

## INSTALLATION

### NOTE:

- This bicycle attachment is designed to be used exclusively with the Honda cross bars which are sold separately.
- Do not use non-Honda accessories, carriers or attachments with this bicycle attachment kit.
- Install the bicycle attachment after installing the cross bars on the roof rails.
- Do not damage the roof and other finished surfaces of the body when installing this bicycle attachment.
- If you are installing more than one bicycle attachment, you may need to alternate the mounting positions (front to rear) to allow for handle bar clearance and key lock access.
- Make sure the tire adapters and the locking clamp lever are installed on the outboard side.

### Installing the Bicycle Attachment

This bicycle attachment kit is intended for installation on the passenger's side. If you are going to install the bicycle attachment on the driver's side of the vehicle continue with steps 1 and 2; otherwise, go to step 3.

1. Loosen the three socket bolts at the bottom of the front plate with the hex wrench included with the kit. Slide the front plate forward as shown.

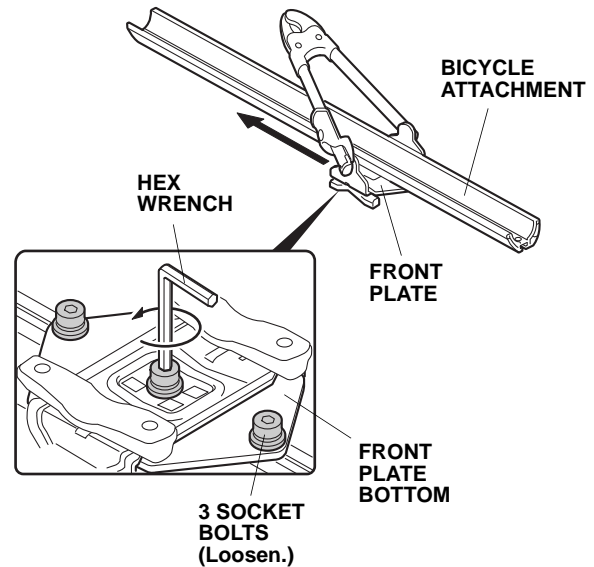

2. Set the front plate 245 mm (9.6 in.) from the end of the bicycle attachment as shown, and retighten the three socket bolts at the bottom. Torque the three socket bolts to 8 N·m (5.9 lbf·ft). Rotate the arm as shown.

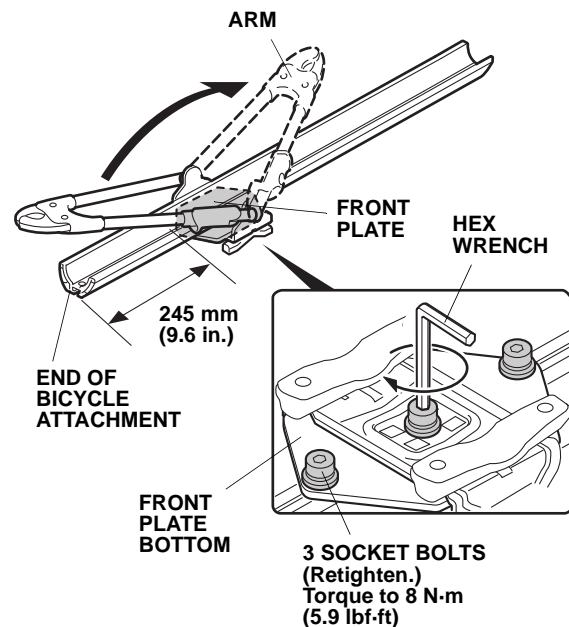

3. Remove the two thumbwheel screws and slide the bracket onto the bicycle attachment.

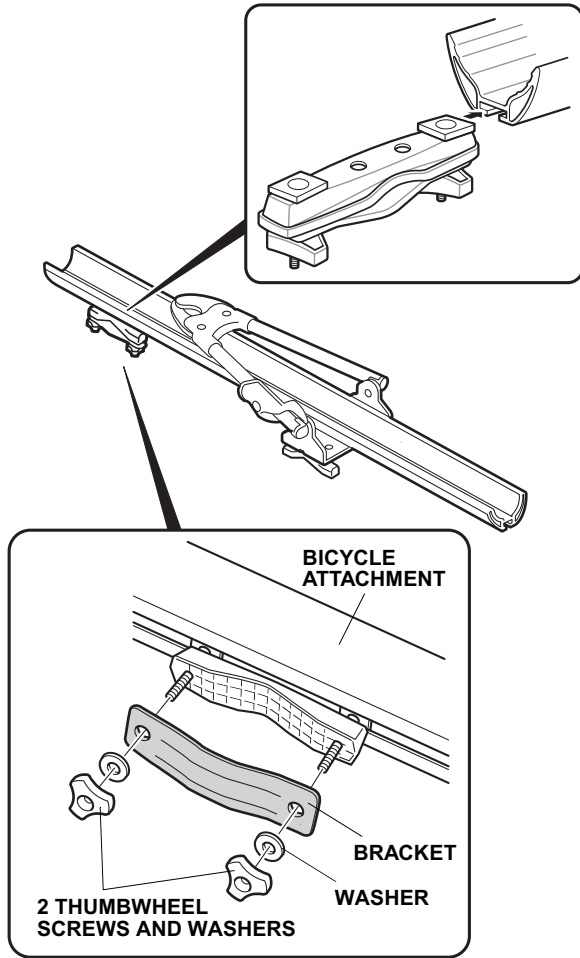

4. Slide the rear plate onto the bicycle attachment.

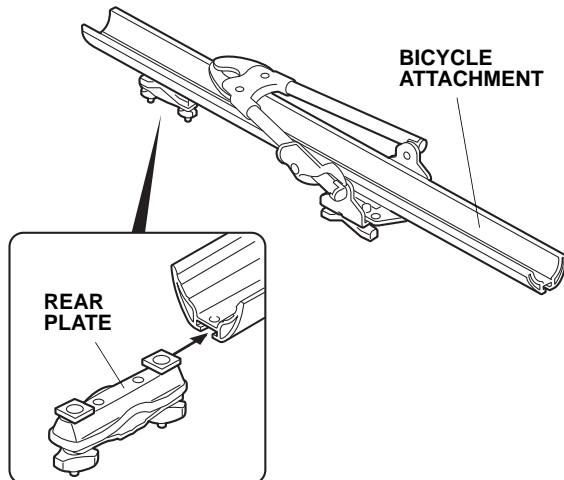

5. Insert the wheel strap into the tire adapter, and slide the wheel strap onto the end of the bicycle attachment. Repeat the same procedure on the other end of the attachment. Make sure that both wheel straps are facing the same way.

### For Installation on the Passenger's Side:

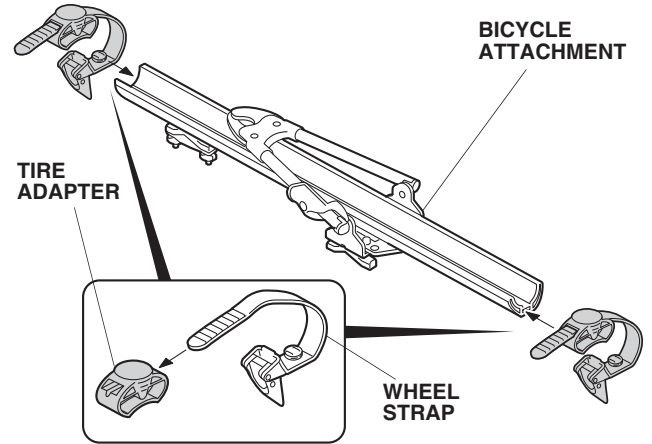

### For Installation on the Driver's Side:

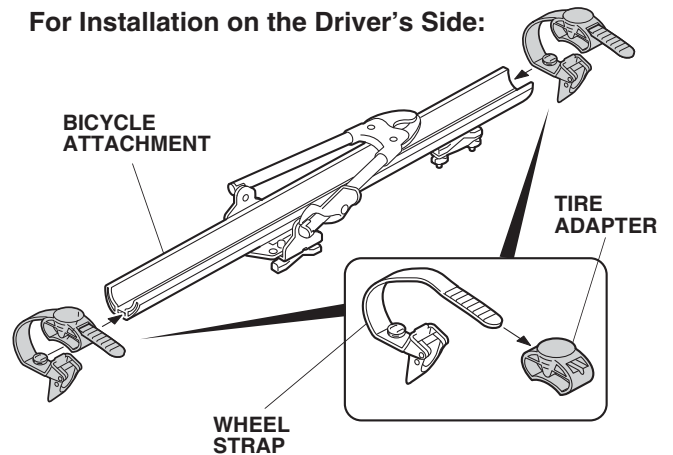

6. Install the end cap onto the bicycle attachment by aligning the lock tab on the end cap with the hole in the bicycle attachment. Push down on the end cap until the lock tab “clicks” into place. Repeat the same procedure on the other end of the attachment. Insert four bolts into the front plate.

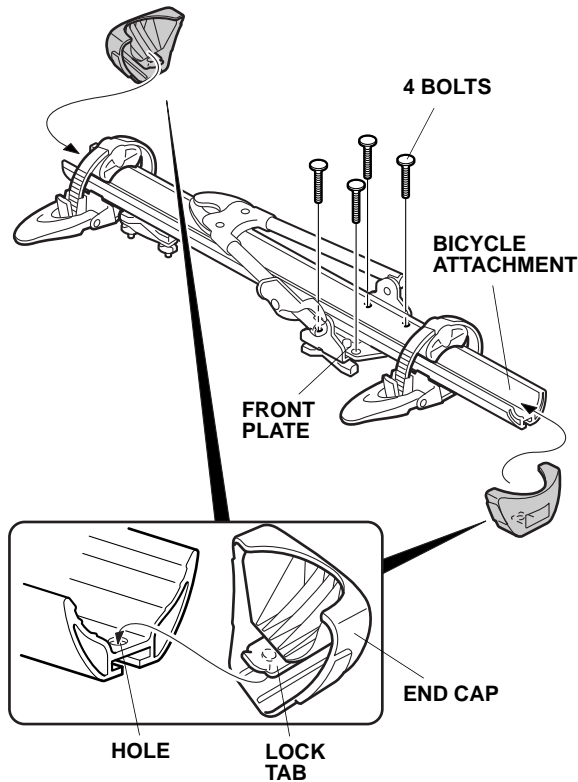

7. Install the bicycle attachment to the cross bar with two knobs, two washers, and one bracket. Repeat the same procedure for the other two positions on the bicycle attachment.

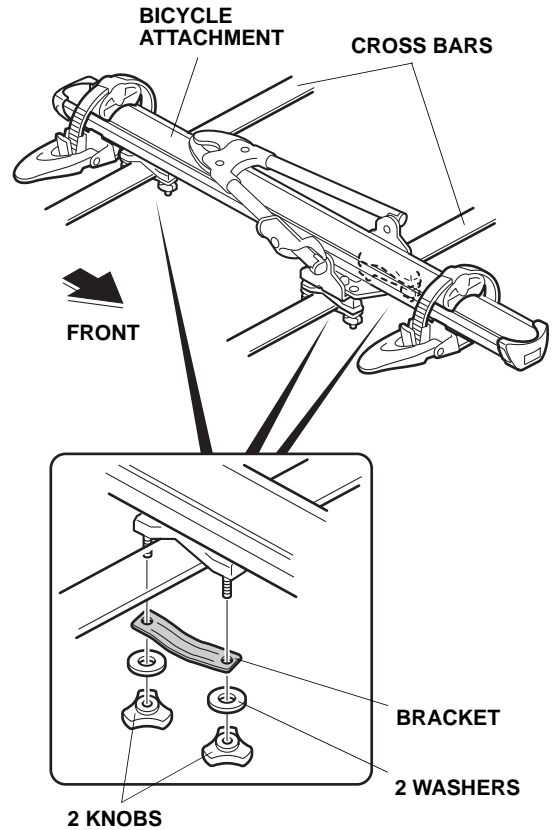

8. Close the locking clamp lever. To deter theft of the bicycle attachment, lock the locking clamp lever with the key.

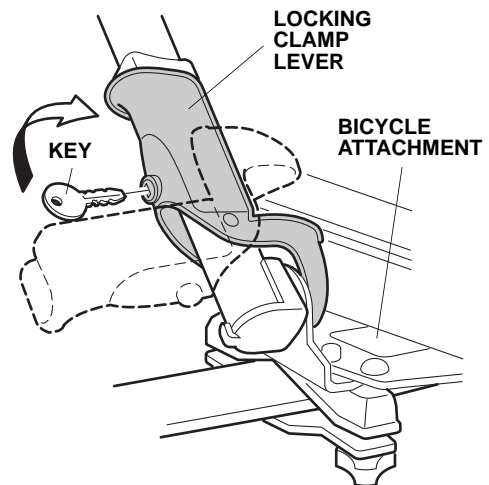

9. Write down the key number in case the key is lost or stolen.

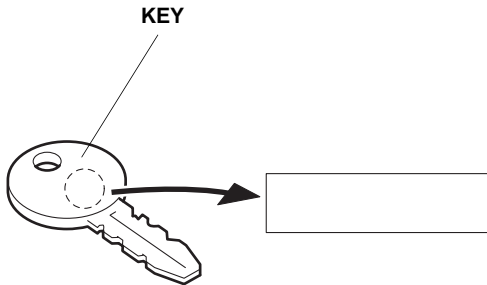

10. Store the key in the glove box for future use.

## How to Install the Bicycle on the Bicycle Attachment

11. Do not carry a bicycle with this bicycle attachment if the diameter of its frame exceeds 55 mm (2.2 in.) or if its sectional view is not circular in the area where it is held by the bicycle holder.

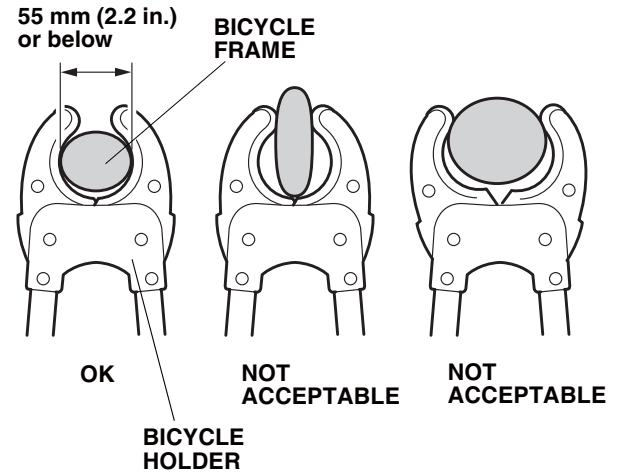

12. Release the locking clamp lever with the key and pull the locking clamp lever down.

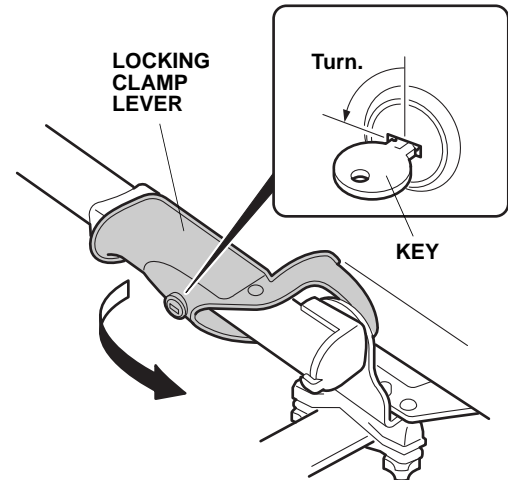

13. Position the bicycle on the bicycle attachment. Lift the arm up, and hold the bicycle frame with the bicycle holder, then push down the slider.

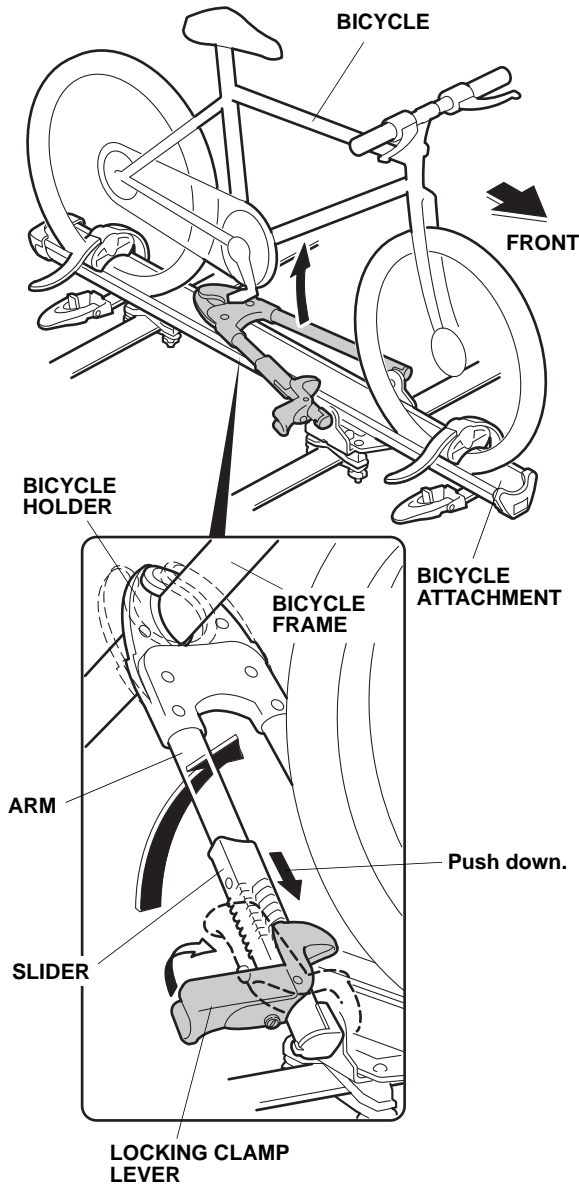

14. Push up the locking clamp lever to secure the bicycle frame.

15. Lock the locking clamp lever by inserting the key into the key cylinder and turning it in a clockwise direction.

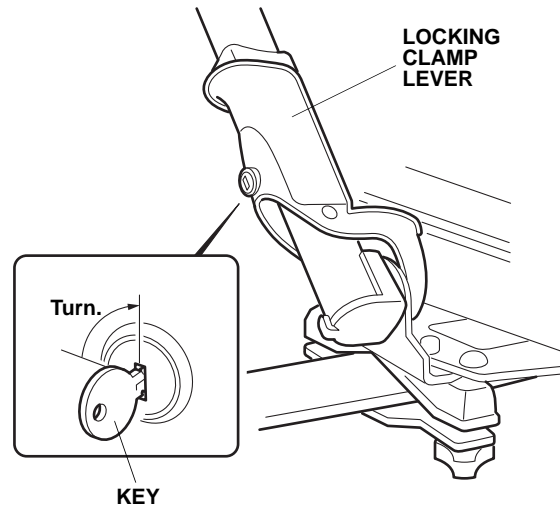

16. Position the wheel straps at the center of the bicycle wheels, and secure the wheels with the wheel straps by inserting the belts through the buckles and locking the buckles in the direction shown. If the size of the bicycle tire is too big to be secured by the belts, reinstall the tire adapters upside down on the belts as shown. Make sure the buckles are fastened securely.

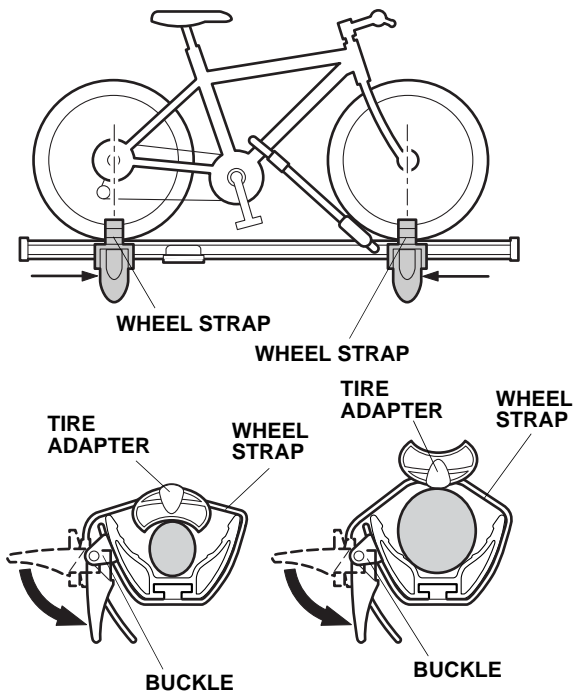

## USE AND CARE

- Addition of the bicycle attachment on the vehicle raises the overall height of the vehicle. Pay attention to overhead obstacles when driving with the bicycle attachment.
- Before and after driving, or after loading the bicycle on the attachment, check the security of the attachment mounts and retighten them as necessary.

## PRECAUTION

- Avoid sudden starts or stops with the attachment on the vehicle. It may cause bolts and other fasteners to loosen.
- Obey local laws and regulations.
- Before driving, check that the attachment is locked securely regardless of whether or not a bicycle is mounted on the attachment.
- Do not use the bicycle attachment with vehicles other than those specified.